

JB-150N-HEAD Wireless valve head

This product is a wireless bi-directional device of the **JABLOTRON 100** series intended for controlling water heat line radiator valves or heat line distributors. A valve head enrolled in the JA-10xK control panel copies selected PG outputs. A maximum of 16 valve heads can be controlled by the control panel.

This product should be installed by a trained technician with a valid Jablotron Alarms installation certificate.

Installation

The wireless valve head (referred to as the valve head) should be installed in a dry indoor environment. Installation is done by the use of a heat line valve adapter.

The JA-11xR radio module must be installed in order to make the wireless valve heads functional with a JABLOTRON 100 series control panel. The valve head must be enrolled in the control panel and takes one position.

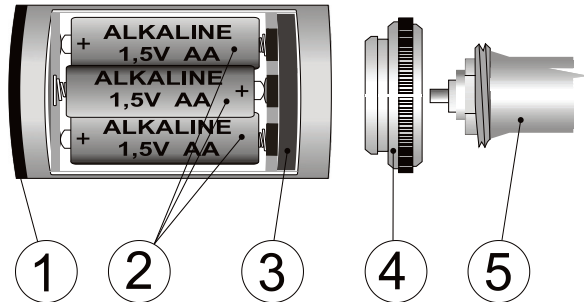

Fig. 1: 1 – indicator; 2 – battery; 3 – safety ring; 4 – adapter; 5 – radiator valve

Installation procedure:

1. Remove the original valve head.
2. Screw a suitable adapter onto the valve. (4).
3. Proceed according to the control panel installation manual.

Basic procedure:

- a. Go to the **F-Link** program, select the required position in the **Devices** tab and launch enrollment mode by clicking on the **Enroll** option.
 - b. Inserting batteries into the valve head will send an enrolment signal to the control panel.
4. Attach the valve head to the adapter.
 5. Close the battery cover.
 6. When the cover is closed, the tamper contact deactivates and the valve head starts calibration for the type of valve used. The result of calibration is indicated by a flashing indicator.
1x Valve detection has been successful.

- 3x Valve detection has been unsuccessful (the valve head will attempt to detect the valve two more times within 3 minutes). If the valve hasn't been detected after the third attempt, make sure that you have selected the correct adapter for the particular valve and that the valve head has been attached correctly. Repeat the calibration process by opening and closing the battery cover.

Notes:

- The valve head can also be enrolled into the control panel by entering its production code in the **F-Link** software. The production code is on a sticker (8) placed under the battery. All numbers stated under the bar code shall be entered (example: 1400-00-0000-0001).
- If communication with the control panel is lost, the valve head will stay in the position of the last processed command from the control panel. Loss of communication is indicated by a lit-up yellow indicator.
- When communication is restored, the valve head will switch according to the current settings.

Valve head settings

Open the **Devices** tab in the **F-Link** software. Use the **Internal settings** option at the detector's position to open a dialogue window with settings:

PG output reaction: Activation by one or more control panel PG outputs. The valve head will open when at least one of the selected PG outputs is active.

Reverse response: This setting inverts the valve head's reaction to a PG output. The valve head will be open when none of the selected PG outputs is active.

Tamper contact:

Enabled – An open battery cover is reported as device tampering resulting in system alarm.

Disabled – An open battery cover is reported as fault with a delay of two minutes (time to replace the batteries).

Note: Do not enable the "Tamper contact" option if you suppose the batteries will be replaced by the user.

Valve head removal and battery replacement

Low batteries are visually indicated by a red indicator (1) flashing twice every 30 seconds or every time the status of the valve head changes. The information is then transferred to the control panel. If the "Tamper contact" function is disabled then it is not necessary to switch the control panel into Service mode before replacing the batteries in the valve head

Strictly use only new batteries of the same type and brand. Always replace all batteries at the same time.

Instructions:

1. Open the battery cover (6) using an auxiliary tool (7).
2. Wait until the pressure piston slides inside the valve head (this will release the valve head from the valve to make installation/disassembly easier).
3. Remove the batteries.
 - a) Now when needed it is also possible to remove the valve head from the valve (not needed for battery replacement). Pull the safety ring away from the centre using a thin tool (7) inserted in the recess of the plastic safety ring (3).
 - b) Remove the valve head from the valve
4. Insert new batteries
5. Close the cover. Calibration will be performed once the cover has been closed. See step 6 in the Installation chapter.

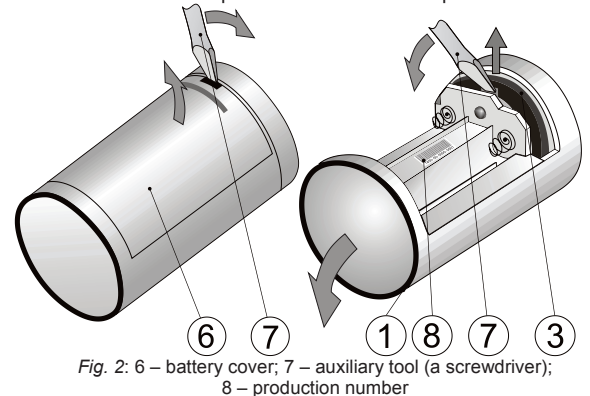

Fig. 2: 6 – battery cover; 7 – auxiliary tool (a screwdriver); 8 – production number

Valve head re-enrollment

Enrolling to a different control panel is done by inserting the batteries just like during installation. The valve head must not be in radio range of the previous control panel.

Valve head accessories

The packaging contains an installation adapter for a valve with a thread size of M30x1.5 (VA 50)

If the VA 50 type adapter is not compatible with the valve used, the other 4 types of adapters listed below can be ordered additionally (5 pieces in the packaging).

- JB-VA78 – diameter 23mm (Danfoss RA)
- JB-VA16 – M28x1.5 (Herz, Polytherm (H), KAN-Therm, Thermoval or Buderus)
- JB-VA26 – (Giacomini)
- JB-VA80 – M30x1.5 (Heimeier, Herb, Ondra, IVAR, Thermoval)

JB-150N-HEAD Wireless valve head

Technical specification

Power	3 x Alkaline battery type AA (LR6) 1.5 V
Current consumption (nominal/maximal)	0.025/550 mA
Protection rating (IP)	IP40
Limit values of the switchgear	T60
Typical battery lifetime	approximately 1 year (10 cycles/day)
Communication band	868.1 MHz, JABLOTRON protocol
Communication range	approx. 300 m (open area)
Dimensions	85 x 49 mm
Weight	105 g
Operating temperature range	0 °C to + 60 °C
	RV 75% non-condensing
Complies with	ETSI EN 300 220-1, EN 50130-4 EN 55022, EN 60950-1 EN 60730-1 ed.3, EN 607-2-8
Can be operated according to	VO-R/10 (ERC REC 70-03)



JABLOTRON ALARMS a.s. hereby declares that the JB-150-HEAD is in a compliance with the relevant European Union harmonisation legislation: Directives No: 2014/53/EU, 2014/35/EU, 2014/30/EU, 2011/65/EU. The original of the conformity assessment can be found at www.jablotron.com - Section Downloads.

Note: Although this product does not contain any harmful materials we suggest you return the product to the dealer or directly to the producer after use.



Valve head removal and battery replacement

Typical lifetime of batteries is 1 year = 1 heating season (10 cycles/day). Low batteries are visually indicated by a red indicator (1) flashing twice every 30 seconds or every time the status of the valve head changes. The information is then transferred to the control panel.

Strictly use only new batteries of the same type and brand. Always replace all batteries at the same time.

Instructions:

1. Open the battery cover (6) using a suitable tool (7).
2. Wait until the valve head motor finishes its motion.
3. Remove the batteries (2).
4. Insert new batteries.
5. Close the cover (within 2 minutes otherwise a fault will be reported). Calibration will be performed once the cover has been closed. The result of calibration is indicated by the red flashing indicator (1).

1x Valve detection has been successful.

3x Valve detection has been unsuccessful (the valve head will attempt to detect the valve two more times). If the problem prevails, the control panel will send fault information to the service technician.

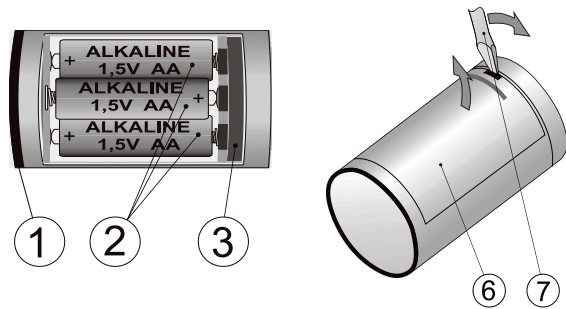

Fig. 3: 1 – indicator; 2 – battery; 3 – safety ring; 6 – battery cover; 7 – auxiliary tool (a screwdriver);