

Signaline Universal Connector Box

The Signaline Universal Connector Box (Signaline UCB) can be used as an end of line enclosure, junction box or an interposing line unit.

It is supplied with appropriately sized cable glands, terminal block and 470 and 680 ohm resistors. It is a quick and efficient method to interconnect, terminate and join lengths of any Signaline Heat Sensing Cable.

It can also be used for connecting the incoming leader cable to the start of a length of heat sensing cable.

The resistors allow Signaline FT cable to be connected directly to the zone terminals of most conventional fire control panels.



Signaline UCB Specification

IP Rating	66
Dimensions (excluding cable glands)	94 x 94 x 57 mm
Material	Impact and flame resistant polycarbonate
Lid Seals	Non ageing polyurethane
Colour options	RAL 7035 Grey
Chemical resistance	Resistant to most acids, alkalis and oils
Operating Temp	-35°C to 120°C

The Signaline UCB is suitable for use with these cables:

- Signaline FT-68
- Signaline FT-68-R
- Signaline FT-88
- Signaline FT-88-R
- Signaline FT-105
- Signaline FT-105-R
- Signaline HD
- Signaline HD-R
- Signaline HD-S

The Signaline UCB is not suitable for use with Signaline FT-185-R

Signaline UCB configurations

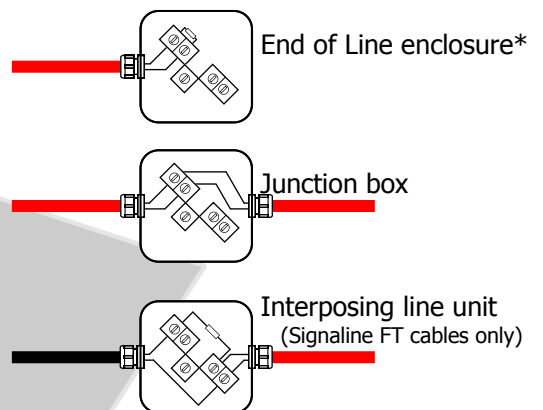

* The end of line monitoring component (such as resistor, capacitor or diode) is not included, this is normally supplied by the control panel manufacturer

LGM PRODUCTS LTD
UNIT 15 RIVERSIDE INDUSTRIAL PARK
FARNHAM
SURREY GU9 7UG
UNITED KINGDOM

TEL +44 (0) 1252 725257
FAX +44 (0) 1252 727627
E-mail sales@Lgmproducts.com
www.signaline.com